

21st CENTURY SCIENCE & TECHNOLOGY

September 2004

www.21stcentury-science.com

ISSN 1525-7529

WHEN
SCIENTISTS
FOUGHT THE ARMY

Science Without The High Priests

- **LaRouche: When Even Scientists Were Brainwashed**



THE SCIENCE OF
THE ADVANTAGE
OF THE OTHER

Pythagorean Spherics: The

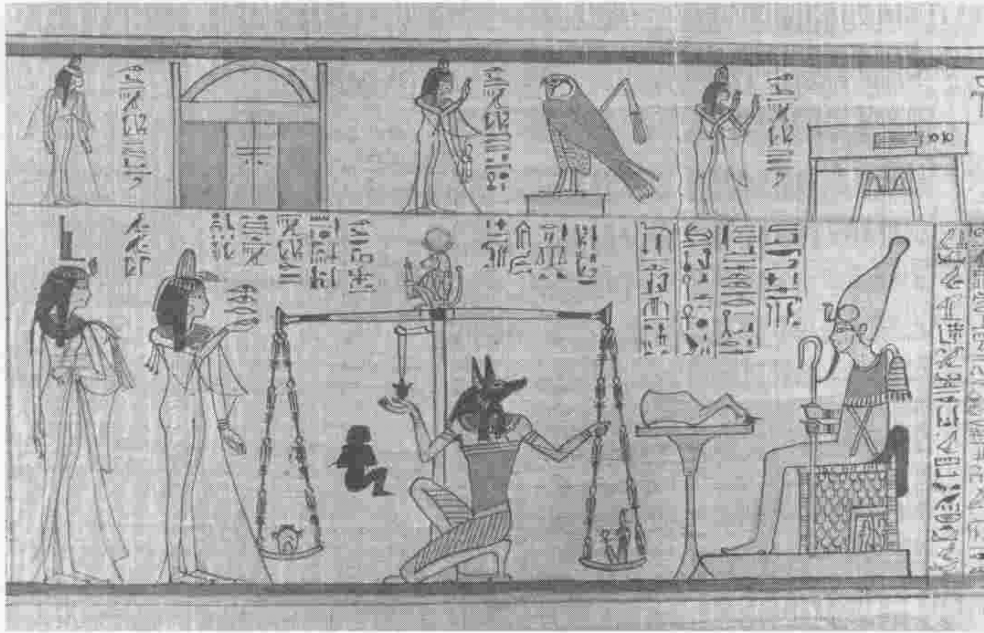

Egyptian funerary papyrus depicting the judging of the dead and the weighing of souls (21st Dynasty). By the Ma'at principle, the heart which is as light as feather (freed of rage and envy) will achieve immortality.

There is no mystery or "secret knowledge" of the pyramid, as centuries of cultists and pyramidiots have alleged. Only the open secret of the science of the "Advantage of the other" lies behind its construction and use.

Missing Link Between Egypt and Greece

by Pierre Beaudry

It was during his stay in Egypt that Pythagoras of Samos (circa 580-504) made the most important scientific discovery of constructive geometry since the construction of the Egyptian pyramids. Pythagoras discovered the application of the principle of divine proportionality, expressed as an ecumenical principle of balance of social justice among human beings. Later, Plato called this principle, *agapē*, in his *Republic*. In ancient Egypt, however, this principle of the common good was called *Ma'at*, or the *Feather of Truth*, and it was expressed as a principle of social fairness that said: *Do unto one as you do unto another*. In Christianity the principle of *Do unto others as you would have done unto yourself* became the expression of the same idea.

During more ancient times, a similar principle, called *Paramatman* in the Sanskrit language, had taken root in India. Later, Saint Paul adopted this same principle of love of mankind, in *I Corinthians, 13*; and also called it *agapē*, a principle for governing both personal and public life.

That principle expressed the capacity of an individual to discover that his true self-interest lay not in himself, but in the interest of others, that is, in their general welfare. The great Indian philosopher, Bal Gangadhar Tilak (1856-1920), had shown, in his book *Gita-Rahasya*, that the ability of the individual self (Atman) to integrate the totality of all other human beings into himself gave access to the absolute universal self (Paramatman): a condition that Mohandas Gandhi had advocated in his own *Gita*, and which can be recognized today in the character of two unique individuals in the world, Pope Jean Paul II, and Lyndon LaRouche. Tilak said that this higher principle required only one condition:

A man must only become ready to achieve the good of others with a desireless frame of Reason. When once

the idea, that all persons are in him and that he is in all persons, has been fixed in a person's mind, the question of whether self-interest is distinct from the interest of others, does not arise at all.¹

The Chinese Analects of Confucius expressed the same principle, and the Golden Rule was translated into the fundamental notions of *ren* and *li*. Thus, the principle of the *common good*, which had become, in ancient times, an ecumenical principle informing ancient Egypt, ancient Israel, ancient Greece, ancient India, and ancient China, became the source of social justice for five great religions, Hinduism, Islam, Judaism, Confucianism, and Christianity.

During the 17th Century, the great French Cardinal de Mazarin introduced this principle in the process of the Peace of Westphalia (1648), under the form of the *Advantage of the other* and instituted it as the principle of diplomacy between sovereign European governments. It was based on this same living principle that the modern form of the Republican nation state had been founded by Gottfried Leibniz, under the appellation of *charity of the wise*, and from which Benjamin Franklin erected the sovereign Constitutional Republic of the United States expressed by the unalienable principle of life, liberty, and pursuit of happiness for the *general welfare* of all the people and its posterity.

This filiation of principle alone demonstrates that the central political issue of mankind throughout history has always been to determine whether man will treat himself and his fellow man as an animal, or whether he will treat himself, and others, as being created in the image of God, that is, in the image of the Creator who loves all of mankind, and promotes its growth. That is all that history is about, and the reason for rediscovering past history is nothing else but to

purposefully rediscover how mankind has been revealing, or has been hiding, that central political issue for the last 2 million years.

1

The Science of the Advantage of The Other: Reconstructing The Pythagorean Missing Link

In the Fall 1992 issue of *Fidelio* magazine, Lyndon LaRouche made an extraordinary conceptual breakthrough in constructive geometry, by establishing a pedagogy of metaphorical thought-objects, that is, a Riemannian *Geistesmasse* for the purpose of political organizing with *agapé*. At the center of his paper, entitled *On The Subject of Metaphor*, LaRouche initiated a re-examination of the nature of the five regular Platonic solids from the standpoint of their Pythagorean spherical origins, and in so doing, raised and provoked a number of questions which remain open to this day. Some of these questions we will attempt to address here. For example:

Why have the Pythagorean spherics been kept secret by the cult of freemasonry for over 2,400 years? Why are the five Platonic solids constructible only from Egyptian Astronomy? Why are there only five regular solids, and why is it impossible to have more than five? Why are three different spheres required to generate the five regular solids? Could there not exist a unique integral sphere generating the five regular solids?

These questions have led us to re-examine Pythagoras and to discover how the Pythagorean method of spherical nesting of the regular solids, represented the actual "missing link" between the ancient Egyptian knowledge of the pyramids and the Greeks, as well as the link between the astronomy of transoceanic-navigators, the Astronauts, and the European legacy of science which was later established by Plato, Nicholas of Cusa, Kepler, Leibniz, Gauss, and Riemann.

Thus, our immediate objective, here, is to revive the Pythagorean method of constructive geometry, and to reconstruct the nesting of the Pythagorean spherical regular solids from the standpoint of their Egyptian principle of proportionality, as expressed by Plato in his *Timaus*, under the form of a correlation between the *orbits of the intelligence in the heavens* and the *orbits of our reason*.

From the standpoint of this higher hypothesis, the constructive geometry of *Spherics* represents a fresh attempt at rediscovering the very beginning of science, and demonstrates that the principle of proportionality was the founding principle of scientific knowledge itself: that is, the science of the improvement of mankind, the science of the *Advantage of the other*. Such was the underlying ordering principle of the universe, as it was understood by the ancient wisemen of Europe, Africa, and Asia, and by means of which the astronomical sphere of the heavens represented the noblest exemplar of a unique relationship between man the discoverer, and God his creator.

We were led to examine the works of Pythagoras as the

missing link between the Egyptians and the Greeks, after recognizing the massive historical evidence of subversion and bowdlerization of the Pythagorean and Platonic doctrines, both by the Aristotelians, and by the neo-Platonic, Gnostic secret societies of Cabalist-Orphic flavor from the Renaissance period until today. That Satanic tradition, coming out of Marcellus Ficino, Pico della Mirandola, and Jean Reuchlin, represented the most significant element of subversion of Plato's doctrine. It formed the basis for the reconstitution of an esoteric, pagan religion based on the Mithra cult of the Roman Empire, whose purpose was to reconcile the mysticism of the Hermes Trismegistus school of Alexandria, the cosmological Cabalistic tradition of Jewish mysticism of early Christianity, and the renegade Benedictine form of mysticism in the Roman Catholic Church, during the first quarter of the 16th Century.

This satanic tradition is represented in modern times by Fabre d'Olivet and his *Golden Verses of Pythagoras*, which follow in direct satanic lineage from the *Harmony of the World* (1525), written by the Venetian Franciscan monk, Francois Georges de Venise, better known as, Francesco Zorzi or Giorgi (1460-1540). Zorzi's *Harmony of the World* was a most extravagant collage of neo-Platonic-neo-Pythagorean-Rabbinical-Cabalistic-pseudo ecumenical concoction. It was Zorzi, who, as the main advisor to the Doge of Venice and the instigator of wars of religion by self-fulfilling prophecies, had sabotaged the anti-Venetian League of Cambrai of 1508 and triggered the so-called wars of religion that lasted from 1511 until the Peace of Westphalia of 1648.²

It was a similar Gnostic cult that not only destroyed Pythagoras' writings and his Italian schools in Crotona and Metaponte, at about 450 B.C., but also totally mystified his doctrine by turning it into a satan-worshipping secret society for the purpose of training an oligarchical elite to rule over human beings like animals, and herd them like cattle.

One thing is certain about Pythagoras, and about the "Pythagorean missing link": Just so much as the power of Greek science is reflected in the original spherics of those five Platonic solids (which are known today as the spherical Octahedron, the spherical Cuboctahedron, and the spherical Icosidodecahedron), in a similar proportion can they be said to reflect the construction principle underlying the Great Pyramid of Egypt.

2

Man in the Image of God: The Original Egyptian Source Of Pythagorean Proportionality

An ancient Egyptian Rhind Papyrus, dated at about 1700 B.C., demonstrates how the Egyptians applied this principle to a method of counting and measuring, which was probably in application during the reign of the first Egyptian dynasties, as early as 3000 B.C. The document revealed a very unique Egyptian method for determining proportionality between entities that were both commensurable and incommensurable. Although the ancient papyrus dealt mostly with practical calculations of determining quantita-

A page from the Rhind Mathematical Papyrus, discovered in the ruins of a small building near the mortuary temple of Ramses II at Thebes. The papyrus shows a highly developed system of arithmetic calculation based on the principle of proportion. The papyrus is named after the original owner, Alexander Henry Rhind; it was purchased by the British Museum in 1865.



tive proportions of tangible goods, in terms of weights and size, the method underlying their calculations showed that their practical use was derived from a higher moral principle of qualitative proportionality, thus, demonstrating that science began with a moral principle, not an accounting one.

In Rhind Nos. 44-46, 49, 51-60,³ for example, the scribe, Ahmose, explained how to determine areas of triangles, how to measure slopes of pyramids and their heights, given the area of their base, etc. One can easily see how Thales and Pythagoras would have been inspired by this contact with Egyptian constructive geometry. For instance, Rhind No. 52 shows how you can transform an irregular truncated triangle into a rectangle by constructing, proportionately, a number of self-similar triangles.⁴ It was the Egyptians who had established that the area of a triangle corresponded to half the rectangle of the same base, and same height. This is the sort of study in proportionality, and similarity, that led directly to the discovery of the Thales Theorem, the Pythagorean Theorem, and the Pythagorean Spherics generating the Platonic Solids. The principle of the Rhind Papyrus revealed the existence of a fundamental underlying process of cognitive thinking, the result of which could be identified simply as a method of just proportionality; that is, a method that *assigns a just apportioning to one as to another*.

It is with such an idea of assigning a proportional, as opposed to an equal share, that the Egyptians developed their sense of social truth and justice, which was echoed in the meaning of *agapē* that Plato discussed in his *Republic*. This had nothing in common with the phony democratic principle of equality, which is so abusively misunderstood nowadays. The Egyptians conceived of it as the principle of a balance, in which, for example, the deceased's heart was

weighed against the *Feather of Truth*, which represented divine justice. If the deceased, whose heart was being weighed, had been devoid of rage and envy, then his heart was as light as a feather. Such a social practice was established for the promotion of the virtue of a person who had internalized, and applied to his actions, during his lifetime, the universal ordering principle of love of mankind, which was represented by the *Feather of Truth*, or the balance of *Ma'at*.

Such a metaphorical characterization of the human heart, being weighed against the lightest physical object, a feather, shows a profound understanding of inverse proportionality, as the German poet Friedrich Schiller demonstrated on the "moral convenience of the heart" in the domain of the sublime. This was, for the Egyptians, the most noble means of measuring truth and justice. It was then reflected in elementary exercises of basic geometric teaching for children, and provided the technology for building the pyramids, which took the form of the *Shadoof* principle.

3

The Egyptian Method Of Apportioning

The Egyptians applied their method of proportionality to the specific case of multiplication; because it revealed, in a metaphorical way, how they thought of the relationship between God, Nature, and Man. Multiplication was made to show how things grow, and how to relate the small to the large. For instance, multiply two numbers such as $33 \times 47 = 1,551$. How do you get to that result by using your mind as opposed to a calculator or blind faith? The Egyptians applied a longhand process of successively growing by self-similarity, that is, by doubling a unit until the first number, 33, was obtained. Next, they applied the same process to the second number, 47 until they reached the sought-for result of 1,551. This process represented the initial means of determining the doubling of any magnitudes, such as the doubling of a line, of an area, and of a volume.

The papyrus showed the following two sets of numbers: *Do unto one as you do unto another*.

/1	/47	or	/1	/47
2	94		/10	/470
4	188		/20	/940
8	376		/2	/94
16	752			
/32	/1,504			
Total 33	1,551		Total 33	1,551

The underlying principle involved here is very simple. Multiplication is nothing but an abridged form of addition, of



Imhotep, whose name means "he who comes in peace," was Chancellor of King Zoser around 3400 B.C. His Step Pyramid Complex was the model and inspiration for all Egyptian pyramids.

weighing more with less. The forward slash (/) represents, in ancient Egyptian notation, the two proportional values that must be added to one another in order to reach the desired total. If you apply a lawful process of transformation to one series of numbers (i.e., doubling), the same apportioning must also be applied to the other series of numbers.

The scribe, Ahmose, applied the same principle to decimals. Then, he added the different columns. In other words, the two series were made to be proportional, within the same order of magnitude; that is, 2 is to 8, as 94 is to 376. The next question then became: Can such a proportionality also be made to exist between two different magnitudes, that is, can you create nonlinear proportionality, say, between a circle and a polygon, between a sphere and a polyhedron, or between God and man? Of course you can. That is what the intention of building the Egyptian Pyramids was all about.

Take a circle and inscribe into it an equilateral triangle. Project from the center of the circle a series of radii, which

divide successively one of the sides of the triangle into 2, 4, 8, 16, 32 parts. Compare the segments of the circle with the segments of the polygon. They are not equal, but they are proportional, although the circle and the polygon are two different and incommensurable species. You have assigned to one the same portions, or shares, as you assigned to the other. That is the Egyptian means of apportioning two different manifolds, or of determining proportionality between two qualitatively different domains. Apportioning between two or more human beings functioned similarly.

It is this process of proportionality that Pythagoras had applied to the principle of man created in the image of God, and that he discovered in the form that became known as the *Harmony of the Spheres*. Just to illustrate the simplicity of the process, examine the following *Pythagorean Table*. Pythagoras transposed the Egyptian method of proportionality to an elementary table of multiplication. The table is made up of a double entry, which gives the product of any two numbers between 1 and 9. As the reader can see, the table could be made as large as one could wish.

1	2	3	4	5	6	7	8	9
2	4	6	8	10	12	14	16	18
3	6	9	12	15	18	21	24	27
4	8	12	16	20	24	28	32	36
5	10	15	20	25	30	35	40	45
6	12	18	24	30	36	42	48	54
7	14	21	28	35	42	49	56	63
8	16	24	32	40	48	56	64	72
9	18	27	36	45	54	63	72	81

This Pythagorean method was merely a practical improvement of the Egyptian principle of multiplication. The product of any two numbers, say $6 \times 8 = 48$, is found at the intersection of the vertical and horizontal lines beginning with 6 and 8. Here, the proportionality follows the simple addition of the initial number of each series.

4

The Proportionality between the Sphere and the Polyhedron: The Anomaly of the Great Pyramid

The discovery of Precession Astronomy can be traced back, in an architectural documented form, to the construction of the Step Pyramid of Zoser at Saqqara (circa 3400 B.C.). This pyramidal complex was the first stone architecture in the world. It was built by Imhotep who was later made the god of medicine, and was remembered as initiating a *golden age of wisdom*. Imhotep, whose name means *he who comes in peace*, was the Chancellor of King Zoser (Djoser, around 3400 B.C.) during the 3rd dynasty and was known to have been a scribe/educator, a vase maker, a sculptor, a physician, a water engineer, a pyramid builder, and the administrator of the Great Palace of the Pharaoh. Imhotep's Step Pyramid Complex was the model and the inspiration for

Divine Proportion

The height of the Great Pyramid (OP) is to the perimeter of its base (ABCD) as the radius (OP) is to the circumference of the circle

Meridian Circle of the Great Pyramid

Side of Pyramid = 762.24 ft
Height of Pyramid = 485.5 ft = radius
Twice the height of Pyramid = 971 ft = diameter
 $971 \times \pi (3.14) = 3,048.94$ ft = circumference of circle
 $762.24 \times 4 = 3,048.96$ ft = perimeter of base (ABCD)

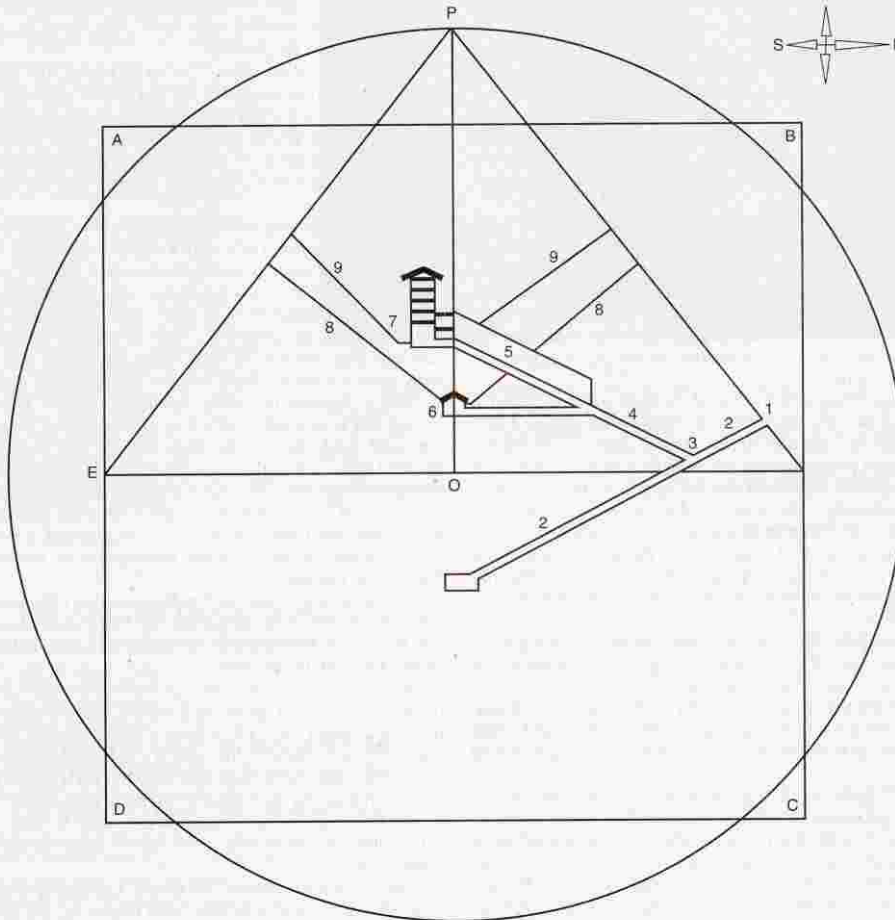

Figure 1
GREAT PYRAMID PARADOX OF SQUARING THE CIRCLE

- | | | |
|--------------------------------|--------------------------------|-------------------------------|
| 1. Entrance of Great Pyramid | 4. Ascending Passage | 7. King's Observation Chamber |
| 2. Descending Passage | 5. Grand Gallery Observatory | 8. Queen's Observation Shafts |
| 3. Location of Reflecting Pool | 6. Queen's Observation Chamber | 9. King's Observation Shafts |

Source: Adapted from J. P. Lepre, *The Egyptian Pyramids, A Comprehensive, Illustrated Reference* (Jefferson, North Carolina and London: McFarland & Company, Inc., 1990)

the construction of all of the Egyptian pyramids, and especially the building of the Great Horizon Pyramid of Khufu (Cheops), circa 3300 B.C.

Between the years 495 and 491 B.C., water-engineer and architect, Khnum-Ab-R'a, who was chief minister of works in Egypt, had left an inscription on a public monument of the valley of Wadi Hammamat, which put on record his 24 architect-predecessors, leading back to Imhotep and his father, Kanufer. This amazing pedigree covered about 2,000 years of Egyptian culture, and encompassed the entirety of known Egyptian civilization.

Since Imhotep was the founding father of all of the Egyptian pyramid builders, it is only fitting and proper that we attribute to him the authorship of the Egyptian principle of proportionality, which may be stated as follows:

The height of the pyramid is to the perimeter of its base as a radius of the same height is to the circumference of its circle. (See Figure 1.)

What this astronomical proportion implies, is that the monument of Khufu, properly understood, represents a metaphor, which identifies and establishes a crucial historical singularity by which the human mind is made proportional to the image of God. The significance of this discovery by Imhotep, corresponds to what Plato later called his higher hypothesis of ordering the *orbits of intelligence in the heavens* with the *orbits of our reason*.

The significance of this Great Pyramid paradox is that it expresses the very foundation of scientific knowledge 5,000 years ago. Its intended purpose was to establish an incommensurable proportionality between God and man, a form of proportionality which was later re-introduced by Nicholas of Cusa, during the 15th Century Golden Renaissance, with the idea that God is to man as a sphere is to a polyhedron. This represents the earliest case study of the significance of the discovery of the principle embodied in the relationship between the nonlinearity of the sphere and the linearity of a polyhedron.

The reader should examine closely the fact that the apex of the Great Pyramid is formed by an angle of 76 degrees (twice 38 degrees). This angular measurement of 38 degrees is also found in the two observation shafts of the Queen's Chamber, which form a 90-degree right angle with the 52-degree angle of the pyramid slopes, two of which form an angle of 104 degrees.

This is quite perplexing, because the uniqueness of this angular arrangement is such that no other combination of angles will establish a proportionality between the height of the pyramid and its perimeter, with the radius of a circle and its circumference. The irony of this paradox resides in the fact that the solution, known as squaring the circle, is incorporated in the very architecture of this pyramid, and yet its explanation cannot be found in the pyramid itself. The solution can only be found in the Pythagorean Spherics which produce the five Platonic solids. This means that the Great Pyramid of Egypt and the Five Platonic Solids are historically bound together, and can never be separated from their common generative principle. Thus, the Great Pyramid casts its historical shadow over Greek and European science and civilization as a whole.

The Pyramidiots

Because of the revolutionary nature of such a singularity, the great majority of Egyptologists have made systematic efforts to obfuscate it by making the claim that the pyramid of Khufu was the magical replica of a hemisphere. Since its original erection, British pyramidiots have attempted to legitimize that view by interpreting the role of the Great Pyramid as the center of a magician cult. This is done by obfuscating the scientific knowledge of astronomy, and then lying that only the initiates of that occult fraternity could have access to the so-called magical secrets of the pyramid.

Khufu holds no such secrets. Do not be fooled. The ancient Egyptian priests presided over the first known scientific discoveries in astronomy and constructive geometry in recorded history. That is the crucial point to make here. From this standpoint, everything about the Great Pyramid of Egypt has a scientific explanation, that even your children will be able to grasp.

The false underlying assumption behind the Masonic cult of the pyramid is that it is in man's nature to become a God. The purpose for such an outrageous satanic claim is population control. That is, the belief that only a small group of elite families (oligarchies) has been chosen, throughout the span of history, to assume the role of treating the rest of humanity like animals: to herd them like cattle, and cull them once in a while. Those families are said to be chosen, by God, to become the ruling divinities on Earth. This is a lie, and this is why the *principle of proportionality* between man and God, had to be kept hidden, and has been replaced by a linear mapping of the sphere unto the plane, raising the fraudulent idea that the Egyptians had discovered the nature of π , and that they could cube the sphere. In other words, the Great Pyramid is not, as claimed, a mathematical model of the Northern Hemisphere of the Earth. That is total nonsense.

The real problem here, is that the Masonic cults assume that only esoteric knowledge for the initiates is possible, and that such "knowledge" is based on pure belief in magic. As a result, the false claim was made to the effect that the so-called *secret of the pyramid* lay in one's ability to translate linearly a spherical quadrant onto a flat pyramidal triangle, and thus, the area of a plane triangle can be magically made equal to the area of a spherical triangle. In other words, the mathemagicians used this trick for the purpose of eliminating the fundamental issue of proportionality, and showing that man can become equal to God. This war against proportionality is the typical trademark of the satanist Zorzi.

Those two distinct species, the sphere and the polyhedron, are absolutely incommensurable, must remain so, and cannot rigorously be considered as equals—in numbers or otherwise. Those two species represent the most crucial paradox of *cognition*, the very basis upon which one can successfully fight against the satanic credulity of the *gnosis*. This is why both Nicholas of Cusa and Johannes Kepler had insisted that the means of comparing curvedness and straightness was truly the fundamental criterion of human cognition, and the precondition for understanding the difference between God and man. The sphere reflects the divine, as a metaphor of the per-

fection of the Holy Trinity, where the Father is the center, the surface is the Son, and the harmony between the two is the Spirit.

On the other hand, the polyhedron reflects the human mind as seen through the same metaphor of the Trinity, but as if his knowledge were projected on the dimly lit wall of Plato's cave. Man stands, in the image of God, proportionately, as is shown by the projection of a gap of imperfection between the spherical curvature and the plane of the polyhedron. It is that incommensurable gap between the polyhedron and the sphere, which can offer the best metaphor of the condition of the human mind with respect to the Creator. If that gap upsets you, if that *inadequacy function* bothers you, then you are ripe for a Martinist séance.

The Greeks learned that from the Egyptians, and the Italian Renaissance learned that from the Greeks: You cannot square the circle, any more than you can cube the sphere. However, you can make them proportional. The way that Imhotep solved this anomaly, was by extending the proportionality to the calendar cycles of precession which he had discovered, and applying it to human life.

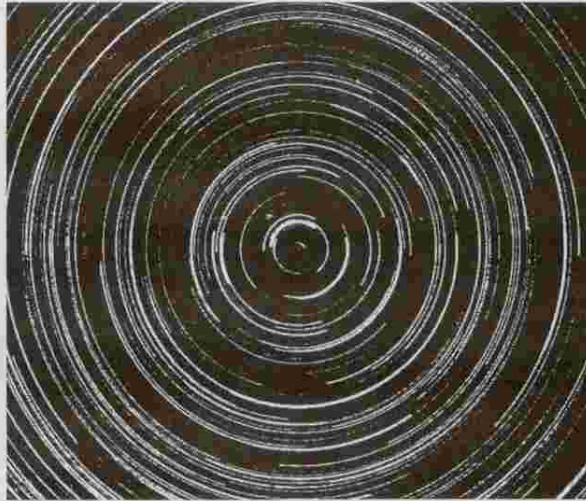

Figure 2

TRANSIT OF STARS AROUND THE CELESTIAL NORTH POLE

Time-delay photograph showing how stars appear to be carried around the north pole of the celestial sphere. Pole stars are any bright star revolving in small circles around the empty center.

Source: Photograph by Richard Anthony Proctor in Peter Tompkins, *Secrets of the Great Pyramid* (New York: Harper Colophon Books, 1971)

5

The Angular Determination of The Great Pyramid

In ancient Egypt, an astronomer once asked an architect: "If you were an astronomer, how would you start building an astronomical observatory which would be perfectly in line with a meridian circle, from which one could observe and teach young people how to determine the transit of all of the stars in the heavens?" In a dialogue with members of his youth movement in Los Angeles recently, Lyndon LaRouche answered that question by saying: "You'd build a deep pit, a deep well, and if the well is narrowly fixed, you can actually see stars during the daytime, and particularly in areas which are fairly arid. And that's when a lot of astronomy was done. They had the nighttime sky, which they were able to survey this way, and also the daytime sky. Motions of the planets and so forth, they could see, in the dusk."⁵

What LaRouche was referring to by his answer is that, during ancient times, the study of angular motions of stars based on spherics led to the discovery of physical principles that went into the construction of the Great Pyramid of Egypt. That is to say, there existed no way to know how far away these celestial objects which rotated around a fixed point in the sky,

as if from the inside of an immense Sphere of the Heavens, were located. Thus, the only way to understand the underlying principle of celestial objects was to determine their regular appearance in the night sky, or in the day sky, and to note the significance of their angular positions when they passed across the narrow slit opening of an observatory, which was in line with the meridian circle of the Celestial Sphere. This required that the observatory be oriented, as perfectly as possible, to the Celestial North Pole of such a sphere (Figure 2).

Thus began the passionate adventure of building Egypt's Great Pyramid of Khufu. Once the location of the bedrock for the Great Pyramid of Egypt was chosen at Giza, the very first step taken was to determine the center of the square floor plan of the pyramid, by establishing the north-south direction of a meridian circle centered at the 30th parallel of latitude. According to Egyptologist Zbinek Zaba, an ancient Egyptian inscription described the ceremony of the "stretching of the cord" to establish the orientation of a pyramid. The inscription said: "Looking up at the sky at the course of the rising stars, recognizing the *ak* [culmination] of the Bull's Thigh Constellation [our Great Bear], I establish the corners of the temple."⁶

Orientation of the Meridian Circle

The Meridian Circle is the great circle of the Heavenly Sphere, which passes through the Earth's True North and cen-

Figure 3
THE POLE STAR
ORIENTATION
OF THE
GREAT PYRAMID

Proctor's drawing shows how the rays of the midday Sun would strike the grand Gallery, during mid-summer, mid-winter, and at the equinoxes.

Source: Peter Tompkins, *Secrets of the Great Pyramid* (New York: Harper Colophon Books, 1971).

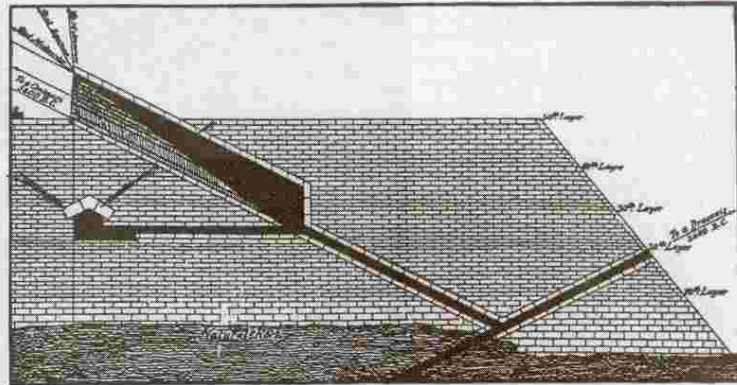

ter, and in whose plane all of the stars culminate at night, that is, reach their highest point of transit (ak), between the Eastern horizon and the Western horizon, as seen from Earth. The transferring of the true meridian from the heaven to the ground, however, required more than a ceremony of drawing lines in the sand. It required the consolidation of an alignment with the Celestial North Pole by digging, as LaRouche indicated, a deep descending passage into the bedrock at the same angle that the chosen North Star projected its ray down to Earth. Since *Alpha Draconis* was the circumpolar star, which was located, at that time, at 3 degrees, 43 minutes south of the Celestial North Pole, the first descending passage of the Great Pyramid was chosen to be in the inclination of its ray, that is, at 26 degrees, 17 minutes.

Midnight would locate *Alpha Draconis* at the floor level of the passage. Thus, the choice of digging a tunnel-like passageway, as opposed to an external ramp, should be obvious: An observer located at the bottom of a deep tunnel can see that star much more clearly, even during the day, than he would at the base of an above-ground ramp of the same length. This initial underground descending passageway was built with such precision that its mean variation from its central axis, along the entire length of 350 feet, is a mere 0.1 inch of latitude and less than 1/4 inch of longitude, with an extraordinary 1/50 of an inch discrepancy near the entrance. The celestial Pole Star was projected directly down that passageway. This meridian alignment was so precise that it is within 3/60 of a degree of True North, a greater precision than that found at the Greenwich Observatory of London, which is off

Figure 4
REFLECTING POOL AT THE JUNCTURE OF THE
DESCENDING AND ASCENDING PASSAGES

By plugging the junction and placing water in it, light could be reflected upward. By looking down the Descending Passage into the reflecting pool, an ancient observer could have noted the exact moment of a star's transit. The same system is used today at the U.S. Naval Observatory, where the daily transit of stars is noted by their reflection in a pool of mercury.

Source: Peter Tompkins, *Secrets of the Great Pyramid* (New York: Harper Colophon Books, 1971).

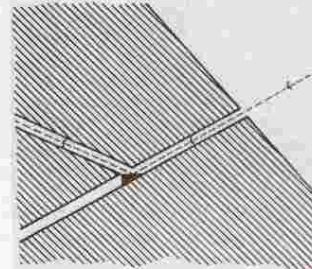

by an error of 9/60 of a degree.

Before the digging ever begins, two things must be known to construct this first observation passage. First, that the same circumpolar stars would come across the meridian at regular intervals of time and would draw small circles around the Celestial North Pole. Second, that this permitted the observer to map the precise timing of stars at their upper or lower culmination, which could be calculated by clepsydras (water clocks). Thus was established, in Egypt, the precise study of marking regular angular periodicity of the heavenly bodies, and the variations in periodicity for longer periods of time. The only way to establish such a universal determination was to have two fixed points around which everything else moved: one on Earth, and one in the heavens. Once these two points were fixed in stone, the building of the pyramid could begin.

Building the Great Astronomy Pyramid

To begin laying the first five courses of stones, the builders had to assure that the ground base was both made absolutely level, and correctly oriented. This was assured by the guiding ascending passageway, which required the fitting of stones precisely in the same inclination of 26 degrees, 17 minutes, and

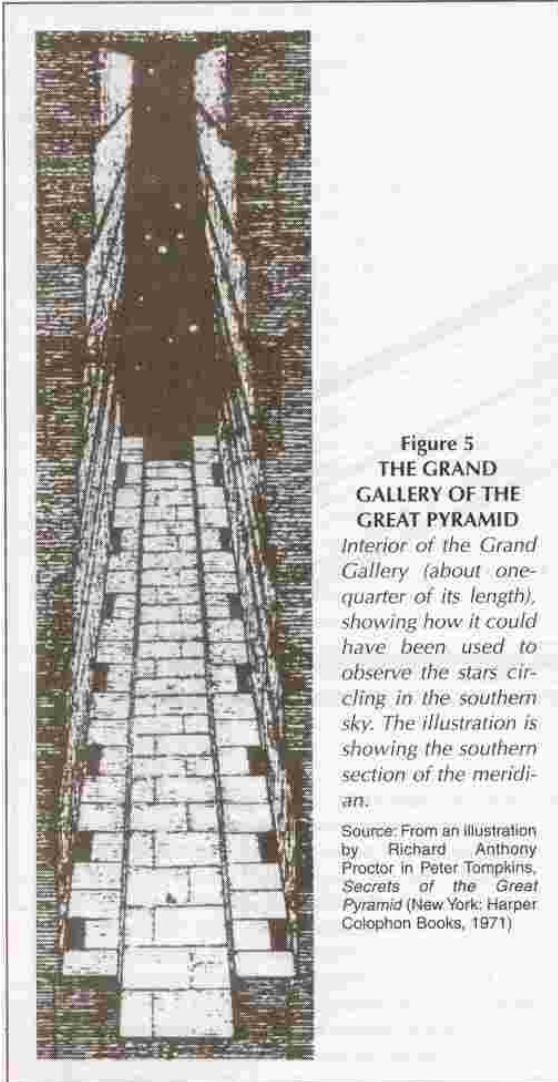

**Figure 5
THE GRAND
GALLERY OF THE
GREAT PYRAMID**
*Interior of the Grand
Gallery (about one-
quarter of its length),
showing how it could
have been used to
observe the stars
circling in the southern
sky. The illustration
is showing the southern
section of the meridian.*

Source: From an illustration
by Richard Anthony
Proctor in Peter Tompkins,
*Secrets of the Great
Pyramid* (New York: Harper
Colophon Books, 1971)

necessitated their positioning in the same northern orientation. Above the fifth course of masonry, a new ascending passage was erected at the same angle of 26 degrees, 17 minutes, but was oriented along the southern meridian. This is the key feature around which was built the rest of the pyramid, up to the 50th course. Those passageways define the axis around which the entire pyramid is built, and provide the only rigorous means of maintaining the constant orientation of the building with respect to the Celestial North Pole (Figure 3). Since the erection of the upper part of the pyramid also required that the same orientation be fixed to True North, it is highly probable that another observation chamber exists, which has not yet been discovered, and which is located in the center of the meridian, at about the 150th course level.

The southern passageway leads to the Great Gallery, to the



**Figure 6
THE TRANSIT CIRCLE
AT THE ROYAL
OBSERVATORY IN
GREENWICH,
ENGLAND**

The meridian alignment of the Great Pyramid was found to be more precisely aligned to true North than the instrumentation of the Royal Observatory in Greenwich, built 5,000 years later.

Source: Peter Tompkins,
Secrets of the Great Pyramid
(New York: Harper
Colophon Books, 1971)

Queen's Chamber, and to the King's Chamber. It was obvious that, once the truncated pyramid reached about the 20th course, which is the level at which the descending passage reached the outside of the growing pyramid, the architects required another way to maintain the orientation of the building in line with the Celestial North Pole. This is when the change of orientation required a reflecting pool, which was located precisely at the juncture of the descending and the ascending passages. At that moment, the builders had to plug the descending passage and fill the upper part of the plug with water so that it could reflect the Pole Star back into the new ascending southward passage. This represented an extremely important moment for the history of science.

The function of this reflecting pool does not merely represent an extraordinary achievement in architectural alignment by means of a reflected ray of the North Star, but implies an understanding of the properties of light and of liquids, at a very early period in time. In fact, the ancient Egyptians were able to discover and apply an early form of the principle of reflection; that is, the principle by which a ray of incidence and a ray of reflection form the same angle with the horizontal plane (Figure 4).

At the level of the 25th course, this passageway opens up into a 28-foot-high Grand Gallery, a feature which maintains an absolute accuracy of orientation with True North for another 25 courses. In other words, the first 50 courses of this giant pyramid had, so far, become a perfect instrument for astronomy, the greatest observatory window on the universe, during ancient times. For all intents and purposes, the Grand Gallery cannot be of any use but for astronomy, and there could never be any satisfactory explanation for its erection, outside of the purpose of astronomy. Modern Egyptologist Peter Tompkins, was forced to concede that the 19th Century British astronomer,

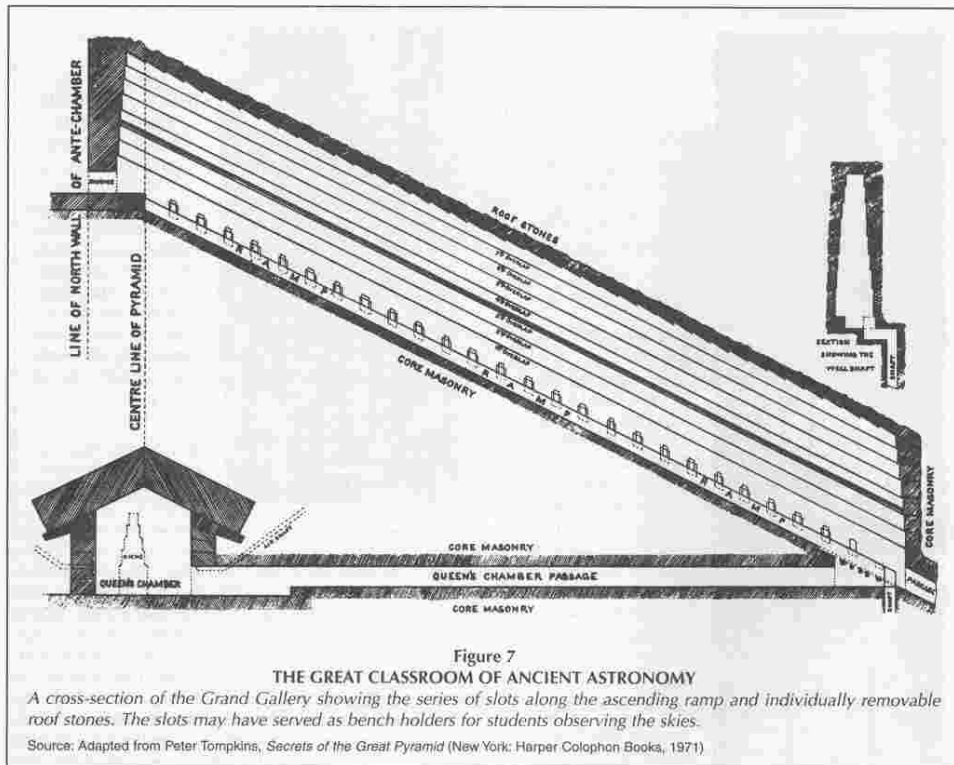

Richard Proctor, was right in his astronomical hypothesis of the Great Pyramid. Tompkins writes:

With various observers in the Grand Gallery, placed one above the other, on the slanted incline, the southing—or transit across the meridian—of every key star in an arc of about 80 degrees, could be observed with remarkable accuracy. As a matter of fact, the most important object of transit observation is to determine the exact moment at which the observed object crosses the meridian. This was obtained by noting the moment when the star was first seen on the eastern edge (left) of the vertical sky space, and when it disappeared past the western edge (right); the instant midway between these two would be the true time of transit.⁷ (See Figures 5 and 6.)

Proctor had understood this purpose very precisely, as Tompkins reported:

Proctor surmises that someone in either the Queen's Chamber or on the flat platform of the truncated pyramid above the Grand Gallery could keep time by hour-

glass or water clock in coordination with the observers in the Gallery, who would signal the beginning or end of transit across the Gallery's field of view.

By looking down the Descending Passage into a reflecting pool, an ancient astronomer could have noted the exact second of a star's transit, because only at that moment will its rays be reflected. The very same system is used today at the U.S. Naval Observatory in Washington, D.C., where the daily transit of stars is noted to a split second by their reflection in a pool of mercury.⁸

The Great Classroom of Ancient Astronomy

One can further ascertain that this Grand Gallery was, in point of fact, a great classroom for Astronomy Studies, in which between 15 and 25 nighttime students would sit on reclining benches positioned at the different levels of the Gallery, and study the transit of all of the stars, in the north as well as in the south of the hemisphere. This would not be so difficult, since the top roofing stones of the Gallery were independently removable plates, before they were covered over by the completion of the pyramid, and there are two series of 27 oblong holes cut vertically into the masonry, which had been

used as bench holders. On the next day, a new group of 15 to 25 daytime students would replace the night class and, with the roof taken off, they would be able to study the shadows of the Sun on the eastern and western walls at different times of the day.

Proctor further suggested that movable horizontal bars, with vertical bars attached to them and marked horizontally, could have been used as a pedagogical device to locate the transit of stars or to locate hourly shadows, at different positions, along the long grooves (6 inches wide and 3/4 inch deep) that appear along the entire length of both walls just above the third overlap. This might have been a way to put on record, with a simple color or numbered code system, the precise angular positions of all of the heavenly bodies traveling through the night sky, from day to day; year after year (Figure 7).

In his article on Proctor, Tompkins concluded:

Proctor adds that for a greater knowledge of the Sun's motion, the Grand Gallery slot could have been used to better effect than an obelisk or a sundial by noting the Sun's shadow cast by the edges of the upper opening against the walls, sides and floor of the long Gallery. To make observations of the Sun more exact, Proctor envisaged the use of screens: by placing an opaque screen at the upper end of the Gallery with a small aperture to receive the Sun's light upon a smooth, white surface at right angles to the Sun's direction, a much magnified image of the Sun would be formed on which any sun spot could hardly have failed to appear. The movements of the spots would have indicated the Sun's rotation on its axis.

The Moon's monthly path and all its changes could have been dealt with in the same effective way, as indeed the geocentric paths of the planets or their true orbits around the Sun: These could have been determined very accurately by combining the use of tubes or ring-carrying rods with the direction lines determined from the Gallery's sides, floor, etc.⁹

At the moment of equinox, each year, the students observed that the entire panoply of stars was returning to its original position, but with a slight delay, thus discovering that each year the vernal equinox itself was moving in the opposite direction. This caused astronomers to note the difference between the sidereal year and the solar year. A finer observation and accounting of this inverse clockwise motion of the entire visible universe, and of the Northern axis of the pyramid itself, permitted the measurement of the greatest angle ever recorded in ancient astronomy, the Angle of Precession, which corresponded to about 1 degree every 72 years, thus covering a full cycle of 360 degrees over a period of 25,920 years.

We can thus conclude, that once the astronomer-architect of the Great Pyramid had located the apparent pathway of the wandering Planets with respect to the Meridian instrument, it was well within the grasp of intelligent pyramid builders, to determine their irregular and retrogressive behavior employing only angular measurements. Only by using such angular proportionality were the Egyptian pyramid builders able to develop (as all People of the Sea before them probably had), a com-

plete understanding of the Solar Hypothesis, and to pass that knowledge along to the Greeks—most emphatically to Thales and Pythagoras.

6 'The Day of the Gods is The Year of the Mortals'

How did Imhotep determine the proportionality of the great solar year cycle in accordance with a millennium tradition? First of all, after studying the record of secular observations of the precession of the equinoxes, which were provided to him by his father Kanufer (a record that historian Herodotus later estimated to be no less than 40,000 years long), Imhotep projected a proportionality between man and the Celestial Sphere as a whole; that is, he established an incommensurable correlation between immortality and mortality. Herodotus reported: "During this time, they [the priests of Heliopolis in Egypt] said, there were four occasions when the Sun rose out of his wonted place: twice rising where he now sets, and twice setting where he now rises."¹⁰

That period of time of about 40,000 years can easily be calculated on the 12 partitions of a zodiac band. Moreover, thousands of years before Herodotus, the Indian Puranas beautifully expressed this same projection, by saying: "*The Day of the Gods is the Year of the Mortals.*"

It was that poetical expression which became the first scientific expression of the partitioning of the circle into 360 degrees! One degree of change on the circle of the ecliptic was made to correspond to 72 years of an average, healthy human life. Then, on account of the fact that this motion was not a real motion, but rather a resting motion of the earth's axis being reflected on the circular path of the celestial pole, at an angle of approximately 23.5 degrees, Imhotep saw in the precession of the equinoxes a measure of infinity, which Plato later called the *moving image of eternity*.

Thus, Imhotep constructed the fixed division of the circle based on a partitioning of 360 years, and applied it to precession; that is, $72 \times 360 = 25,920$. For that purpose, he established the following series of apportioning in which the lifetime of man was made proportional to the cycle of the great year of precession.

1	360
2	720
4	1,440
/8	/2,880
16	5,760
32	11,520
/64	/23,040
Total = 72 years	Total = 25,920 years

The forward slashes / represent, in ancient Egyptian notation, the two proportional values that must be added to one another in order to obtain the desired total. The values of 8 + 64 = 72 are proportional to 2,880 + 23,040 = 25,920. Thus, the multiplication of $72 \times 360 = 25,920$ becomes the metaphor of the proportionality of the two different mani-

folds, in which one lifetime of man: 1/360 is made proportional to the great solar year, or the day of the gods, 72/25,920.

Look at the four shafts and the two rooms of the pyramid, not as the remnants of some mystical cult of the dead, as British pyramidiots like to make believe (no body of a dead person has ever been found in any of the Egyptian pyramids), but as components of an ancient astronomical observatory, the great Star Clock of ancient time. Such observation components related to the yearly cycle of 12 months of 30 days each, plus 5 and 1/4 additional god-given days, corresponding with the birthdays of Osiris, Isis, Horus, Set, and Nephthys. Thus, the Egyptian calendar of $12 \times 30 + 5$ and $1/4 = 365.25$ days. This yearly calendar was regulated on the fixed and non-apparent motion of the axis of the universe as a whole, that is, with the return of *Alpha Draconis* to its original position, 25,920 years later.

The seasons of the living were established from the heliacal rising of Sothis (Sirius), thus marking the beginning of the New Year at the summer solstice each year, and dividing the year into three seasons of four months each ($3 \times 120 = 360$). Each year was partitioned into 12 months of 30 days each ($12 \times 30 = 360$). In other words, what these simple determinations of time indicated by the Egyptian Calendar was closure: They reflected the existence of knowledge, going back thousands of years, about an ordering principle of the universe which was not arbitrary, nor mystical, but which was defined by boundary conditions set by the spherical nesting of the five regular solids, which were held together in the simultaneity of eternity by a proportionality between the *orbits of the intelligence in the heavens* and the *orbits of our reason*.

That is the key to understanding Pythagorean spherics, and the necessity of deriving the five regular solids from this Egyptian solar calendar astronomy. Thus, the proportionality principle provided an answer to the question of the uneducated peasant, or the credulous believer, who wondered what kind of hooks were holding the heavens and prevented them from falling.

Lastly, think of the pyramid of Khufu as being the Great Clock of ancient astronomy. Nowadays, when people no longer have time for great ideas, a timepiece is reduced to having merely three pointers; the second, the minute, and the hour. That is the timepiece of the stock market in which, every second counts. Ironically, for real human beings, the longer waves of history are truly the most important, because they partake of simultaneity of temporal eternity. From that vantage point, consider that the timepiece of Khufu had five different markers: (1) The daily cycle of 24 hours; (2) the yearly Sothis (Sirius) cycle of 360 days (plus 5.25 god-given holy days); (3) the Sothis (Sirius) cycle of 1,440 years (plus 21 god-given years); (4) the period where "the Sun sets once where it now rises," 12,960 years; and (5) the period of the Great Solar Year of precession, 25,920 years.

In that time frame, the Great Clock of the Khufu pyramid was, and shall continue to be, in harmony with the simultaneity of eternity, because Imhotep and his associates had acquired knowledge of the Great Proportion as a higher hypothesis; that is, the proportion in which the year of the mortals is coherent with the day of the gods. This is how true

time, or simultaneity of eternity, became identified with the axis of the moving sphere of the heavens.

These were the numbers that the ancient Egyptians derived from astronomical observations to determine the proportionality of human life with the great solar year. Compare these ancient figures with those of the Greek, Hipparchus, during the 2nd Century B.C., and note the closeness of Imhotep's record with today's figures, calculated in degrees around the circle of the Ecliptic North Pole:

Estimates	Imhotep	Hipparchus	Today
1 Degree	72 years	78.26 years	71.6 years
30 Degrees	2,160 years	2,347.8 years	2,148 years
360 Degrees	25,920 years	28,173.6 years	25,776 years

I have to caution, however, that this simple Egyptian arithmetic construction has nothing to do with numerology. This is the simple higher hypothesis of proportionality exemplified, as we shall see, by the spherics of the five Platonic solids. There are no secret numbers written in the sky, or in the Pyramids, for that matter. These calendar numbers are merely shadows, indicating that solar astronomy is proportional with the human mind. As Nicholas of Cusa pointed out in *The Layman on Mind*:

Rather, they [Pythagoreans] were speaking symbolically and plausibly about the number that proceeds from the Divine Mind of which number, a mathematical number is an image. For just as our mind is to the infinite Eternal Mind, so number that proceeds from our mind is to number that proceeds from the Divine Mind.¹¹

These cycles are like the clock pointers reminding us that the cosmos is governed by an ordering principle which Plato called *hylozoic monism*, and which expresses itself in the triple self-reflexive harmonic ordering of both the cosmic design of the physical universe, and of the human mind created in the image of God. Thus, are connected the three primary orbs of the day, the year, and the motion of the universe as a whole.

7

The Spherical Means of The Five Platonic Solids

The spherical system that was used in the construction of the Khufu (Cheops) pyramid was the first approximation of what became known in modern astronomy as the horizontal system of coordinates. It is composed of the following three great circles:

(1) A Horizontal Great Circle was made concentric with the center of the pyramid, and intersected the celestial sphere with a very large radius pointing to true north at the intersection of a meridian circle.

(2) A Meridian Great Circle cutting the base of the pyramid and the horizon circle in half, from south to north and at right angles, intersecting the north star, *Alpha Draconis* at 26 degrees, 17 minutes, visible through the descending passage of the north face of the pyramid.

(3) A Zenith Great Circle cutting the pyramid and the horizon circle in half, from east to west, which was made to rotate downward to intersect Sothis (Sirius) star on the meridian circle at the elevation of 38 degrees from the center of the pyramid, through the observation shaft on the southern face of the Pyramid. (See Figure 8.)

This construction of three great circles can be made to intersect different azimuth circles (*almucantars*) describing different positions of all of the stars of the northern celestial hemisphere, including the ecliptic trajectory of the Sun on the equinox, during their daily motions, and determine the altitude and azimuth position of any star at any moment of the night. If one intersects those three great circles of hoops, as described initially, the respective circumferences will mutually divide each other into four equal parts, producing eight quadrants formed by eight regular spherical triangles held together by a total of twelve arcs, forming an octahedron.

If a similar construction is attempted with the use of four and six hoops, the results will be astonishing. Four hoops will generate the spherical Cuboctahedron (the edge mid-point truncation of both the Cube and the Octahedron, which will display eight regular spherical triangles and six spherical squares, a total of 14 figures, 12 intersections, and 24 circular arcs. All four circles divide each other into six equal parts. The Tetrahedron is

also derived from this spherical combination. This astronomical construction corresponds to the *nycthemeron* division of the 24-hour day of 12 hours of nighttime, and 12 hours of daytime.

When you construct a sphere with six great circles, you generate the spherical Icosidodecahedron (the edge mid-point truncation of the Icosahedron and of the Dodecahedron). This construction will display the partitioning of the sphere into 20 regular spherical triangles and 12 regular spherical pentagons. The total number of intersections is 30, and the number of spherical arc segments is 60. All 6 circles divide each other into 10 equal parts. (See Figure 9.)

These were the three primary spheres that Kepler referenced for the construction of the Pythagorean model of the Solar

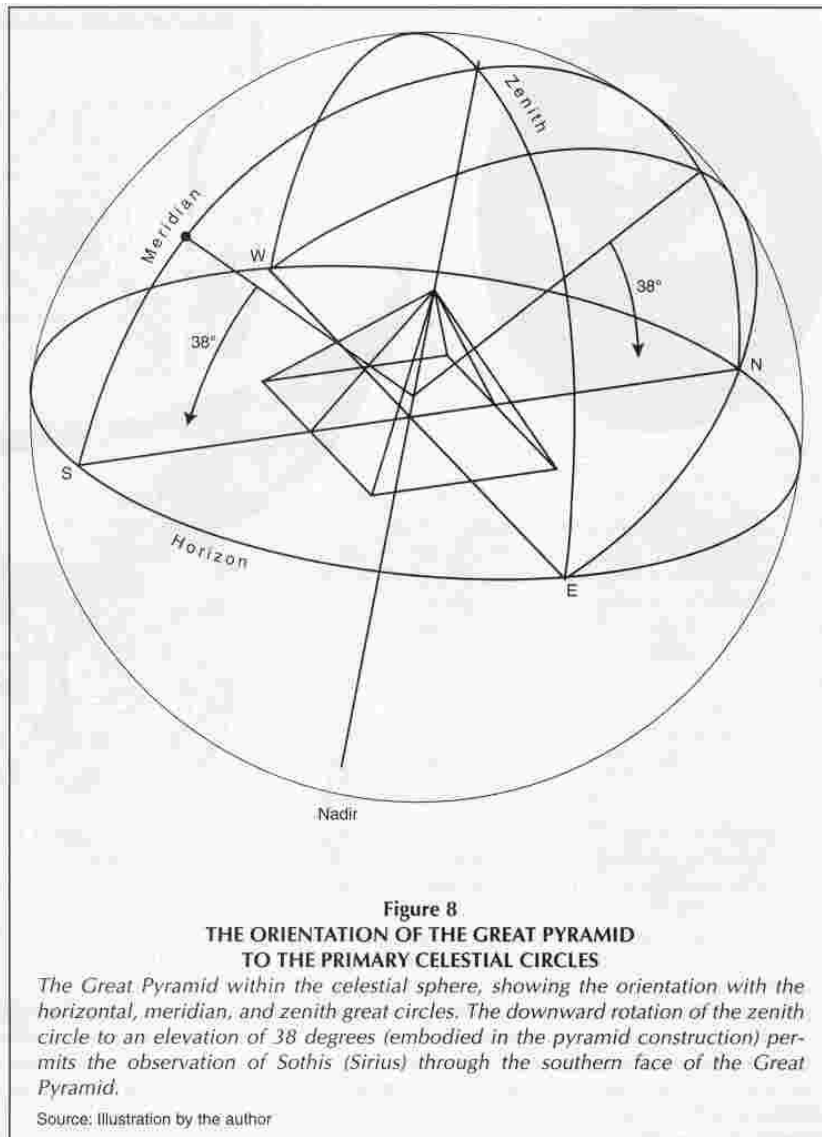

Figure 8
**THE ORIENTATION OF THE GREAT PYRAMID
TO THE PRIMARY CELESTIAL CIRCLES**

The Great Pyramid within the celestial sphere, showing the orientation with the horizontal, meridian, and zenith great circles. The downward rotation of the zenith circle to an elevation of 38 degrees (embodied in the pyramid construction) permits the observation of Sothis (Sirius) through the southern face of the Great Pyramid.

Source: Illustration by the author

System. However, Kepler introduced a crucial anomaly by mentioning a fourth sphere of 10 circles. Let us examine the Pythagorean spheres again, a little more closely.

8

The Kepler-Pythagorean Hypothesis

According to Kepler, Pythagoras had established the spheres of the heavens following the spherical arrangements from which were generated the five regular Platonic solids. It was from that initial Pythagorean spherics construction that Kepler wrote his book *Mysterium Cosmographicum*. He expressed his finding of the Pythagorean constructive geometry as follows:



Johannes Kepler (1571-1630), founder of modern astrophysics.

An engraving of Kepler's determination of the orbits of the planets, from his *Mysterium Cosmographicum*. The planetary radii are determined by a nesting of the five Platonic solids, each solid having an inscribed and circumscribed sphere. Kepler's ordering of the solids, beginning from the circumsphere defining the orbit of Mercury, are: octahedron, icosahedron, dodecahedron (of which the insphere is Earth and the circumsphere is Mars), tetrahedron, cube.

The model which Kepler describes as made from great circles, has been lost.

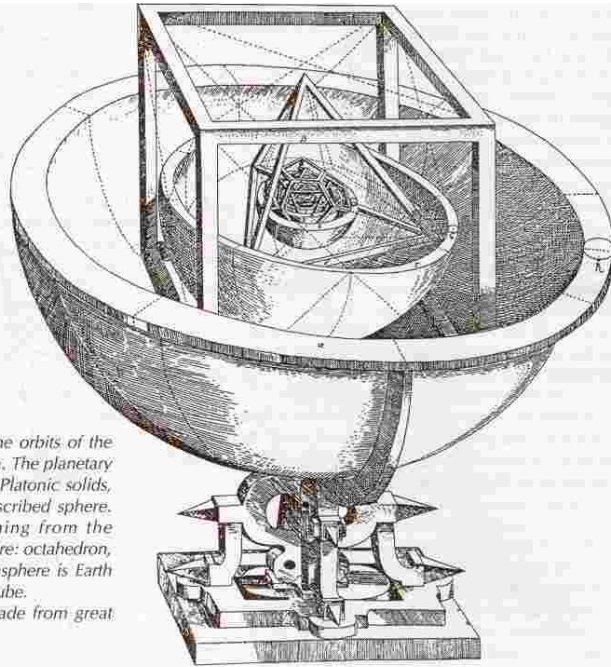

I alluded to the sphere of the planetary system, constructed of the planetary spheres, and the five regular Pythagorean solids, each distinguished from the others by their own colors, the orbits sky-blue, and the bands in which it was implied that the planets ran round, white; all transparent, so that the Sun could be seen suspended in the center. The sphere of Saturn was represented by six circles, which by their common intersections, three at a time, signified the position for the vertex of the cube, but intersected two at a time over the position of the center of a face of the cube. The outermost of the spheres of Jupiter was shown by three circles, its innermost by six circles, and the outermost of Mars again by six; but the innermost of Mars, just as were both those of the Earth, and the outermost of Venus, were each sketched out by ten circles, of which five met 12 times, every three 20 times, and each pair 30 times. The innermost sphere of Venus coincided with the outermost of Jupiter, that of Mercury with the innermost of Jupiter. It was a not unpleasing spectacle, of which the elements, though not an exact likeness, may be seen in the third engraved figure which follows.¹² (See illustration.)

For Pythagoras, the spherical composition of the five Platonic solids was the ultimate expression of the proportionality between the "orbits of our reason" and the "orbits of intelligence in the heavens." Thus, the only way to recast the set-

tings of the five regular Platonic solids from astronomy, is to proceed in light of what Kepler had investigated in his *Mysterium Cosmographicum* with respect to this original Pythagorean higher hypothesis of proportionality. Recall, here, that Kepler explicitly described another Pythagorean sphere made of 10 disks:

...but the innermost of Mars, just as were both those of the Earth, and the outermost of Venus, were each sketched out by ten circles, of which five met 12 times, every three 20 times, and each pair 30 times.¹³

This alone creates a formidable anomaly that did not escape Kepler.

On the one hand, this does not represent a problem in terms of astronomy. The relationships of 12, 30, and 60 refer explicitly to the determination of the zodiac of the celestial sphere spread out in 360 degrees, divided into 12 equal portions of 30 degrees each. Thus, the simple arithmetic $5 \times 12 = 60$, $3 \times 20 = 60$, and $2 \times 30 = 60$ is coherent with precession solar astronomy. These relationships also reflect the minute, the hour, the day, and the annual orbit, as well as the great year of precession. Furthermore, the relationship of 5 circles and 12 figures is an obvious expression of the dodecahedron, just as the 3 circles and 20 figures are an expression of the icosahedron.

But a sphere of 10 circles merely reproduces the dodecahe-

dron, which has already been generated by 6 circles. Moreover, the great circles of the 10-circle sphere are not equally divided. This is a very perplexing anomaly. Also, the four-circle Cuboctasphere (which is made up of great circles partitioned into equal parts), is inscribed into the 10-circle sphere, whose great circles are no longer partitioned into equal parts. Why would Pythagoras do that?¹⁴

Recall what LaRouche had pointed out in his paper "On the Subject of Metaphor," cited earlier:

It can be proven that there are no other partitions of the sphere resulting in the division of the great circles into equal parts. From the limiting case of six hoops, which permits the construction of twelve pentagonal faces, is demonstrated the primacy of the dodecahedron and relative uniqueness of the five Platonic solids. From the six-hooped figure containing dodecahedron and icosahedron, the cube, octahedron, and tetrahedron may be readily derived.

Since it can be proven by construction that all of the Platonic solids can be derived from the single dodecahedron, the statement of LaRouche holds true, absolutely. However, why did Pythagoras introduce a new sphere of 10 circles?

9

The Golden Section as the Limit of Packing for the Five Platonic Solids within Positive Curvature

Restate the conclusive argument of LaRouche to the effect that 6 hoops is the limit of partitioning of the sphere into equal parts. No other sphere can be constructed on the principle of equal partitioning. That is absolutely the case, which will be proven herewith. The characteristics of all of the five regular solids are such that each has the same size face, formed with either equilateral triangles, squares, or pentagons, and each is provided with the same solid angles. Although the requirement for the existence of each and all of the five Platonic

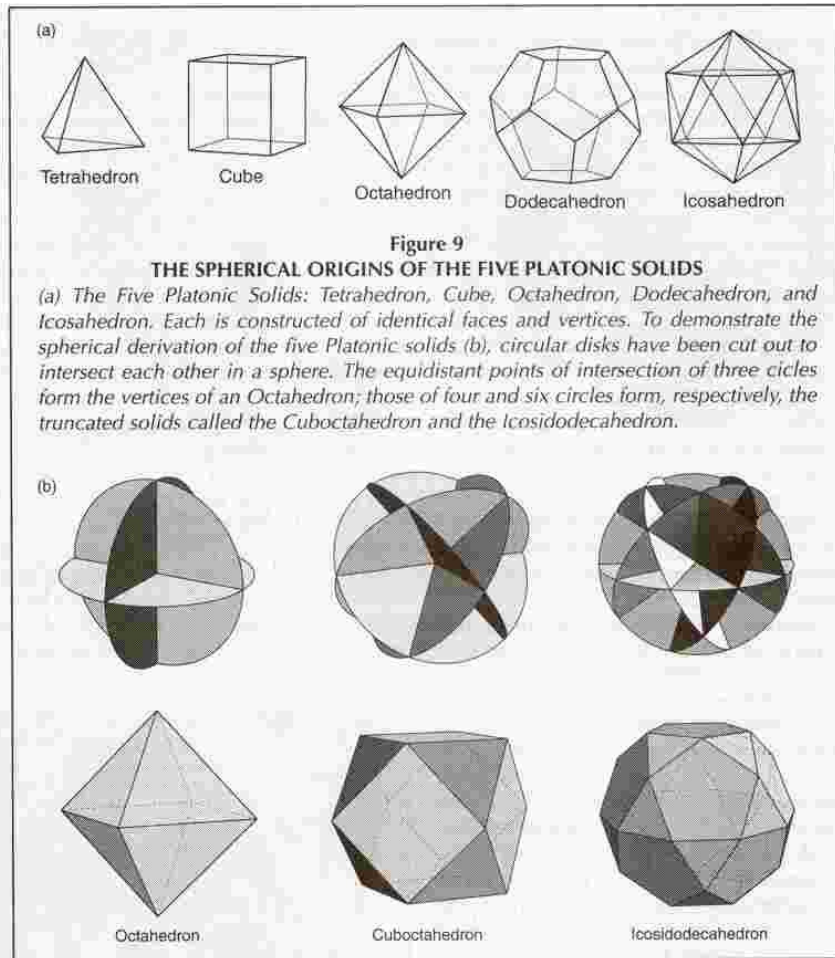

Figure 9
THE SPHERICAL ORIGINS OF THE FIVE PLATONIC SOLIDS
 (a) The Five Platonic Solids: Tetrahedron, Cube, Octahedron, Dodecahedron, and Icosahedron. Each is constructed of identical faces and vertices. To demonstrate the spherical derivation of the five Platonic solids (b), circular disks have been cut out to intersect each other in a sphere. The equidistant points of intersection of three circles form the vertices of an Octahedron; those of four and six circles form, respectively, the truncated solids called the Cuboctahedron and the Icosidodecahedron.

solids, taken individually, is equality, this condition is not the primary feature of their generative principle. Equality may well be the condition for their existence, but it is not the condition for their being generated. Equality is merely an illusion of the linear manifold of sense perception. In fact, equality is the shadow of a higher principle of proportionality, which is its generative principle.

Let us restate this differently. The principle that generates the line cannot be found in the line, but in the surface. Similarly, the principle generating the surface cannot be found in the surface, but can only be derived from the solid. For the same reason, the principle for generating the solid cannot be found in the solid, and must be generated from the sphere. In this generative manner, the surface is to the line as the sphere is to the solid.

Thus, it is in that manner only that we must seek to discover the sphere that generates all of the five Platonic solids as their final cause which has been informing their equality from the beginning. As LaRouche has taught us, the whole is never the sum of its parts; the existence of each part is dependent on the whole, which is primary and exists outside of its parts. Just as the

whole is primary to its parts, lives outside of its parts, and cannot be generated from its parts, so divine proportionality is primary, lives outside of equality, and cannot be generated by equality.

That is the required proof demonstrating that the five Platonic solids cannot be constructed from a principle of equality found within each of the five solids. In fact, their "equality" is but a shadow of the inequality of the Divine Proportion. Thus, in living processes, as in non-living processes, Kepler insisted that equality in numbers or in solids, was "the result of geometric necessity, which follows after they have been constituted." Before their separate existence, however, the law of their mutual transformation expresses a higher power, which is derived from their divine proportionality as primary.

This divine proportionality produces, here, a special kind of ambiguity in which six-sidedness is mixed with ten-sidedness. Bear that in mind for a little while. That is the anomaly to be resolved. What does that mean? It means that during their pre-existing condition, or during their generative phase of existence, the Five Platonic Solids did not exist separately, and could only be thought of as existing in a form of a special ambiguous mixture; that is, in the form of *this is to that*, as *that is to this*, and being neither this or that, within the divine creative process of their formation, which also pertains to the nature of metaphor.

Consider, for example, that the Cuboctahedron is the mean proportional between the Cube and the Octahedron, just as the Icosidodecahedron is the mean proportional between the Icosahedron and the Dodecahedron. This proportional process of formation can even produce intermediary proportional forms or means, which are called "semi-regular solids," and which differ from Platonic solids by having a number of additional hexagonal or other polygonal faces. Moreover, their condition of existence within their spherical formation is also divine, in the sense that they are all proportional means of each other.

This is what it means to be social. When this is developed in a republican form of society, it produces such harmonic beauty that Leibniz called it the most excellent state of social existence in the universe, the best of all possible worlds. It is this condition of proportionality that Leibniz emphasized in his *Outline of a Memorandum: On the Establishment of a Society in Germany for the Promotion of the Arts and Sciences*, and applied to the government of a Constitutional Republic:

All beauty consists in harmony and proportion; the beauty of minds, or of creatures who possess reason, is a proportion between reason and power, which in this life is also the foundation of the justice, the order, and the merits and even the form of the Republic, that each may understand of what he is capable, and be capable of as much as he understands.¹⁵

All human beings are born equal. However, human beings do not develop equally. Each is given a unique talent, to be discovered and to be developed, not for one's own sake but for the *Advantage of the other*. That is the republican form of justice, as opposed to democratic equality. Without this principle of *agapē*, there is only the barbaric condition of cattle-like victims and predators under the universal fascism of an oligarchy.

Under the guidance of the same principle, Kepler discarded the so-called "counting numbers" as having no existence in and of themselves. Kepler insisted that there be a geometric necessity to "counting numbers." The underlying principles of the universe must therefore primarily apply to a geometric principle, from whose arrangements, numbers are to be considered as merely derived, as shadows cast on the dimly lit wall of Plato's cave. By relating the four elements (air, fire, water, earth), and the heavens to the five regular solids, Plato created a thought-object that he called the phase space of change.

This is how, according to Plato, God used the generative function of divine proportionality to create different things—crystals, plants, human beings—which express, each according to its own powers, and more or less remotely, their original divine proportional mixture. Plato attributed this function to a nurse of generation that he named *chora*, the divine phase space of change, which organized the physical universe. As Plato put it in his *Timaeus*:

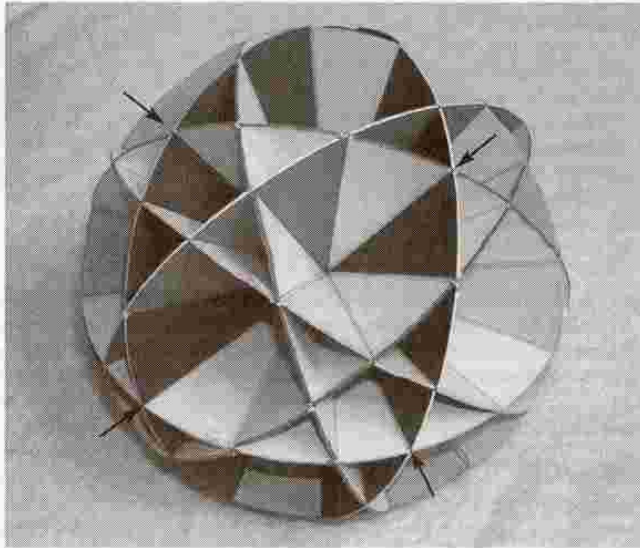

Figure 10
THE 10-CIRCLE SPHERE

The author's construction of a 10-circle sphere, showing one of the square faces (the four corners are marked by arrows). Three of the 12 pentagonal stars can be seen by examining the pentagons and their star-like triangular extensions.

This identifies the crucial singularity in the construction of the Great Pyramid.

Thus, have I concisely given the result of my thoughts, and my verdict is that being and space (*choran*), and generation, these three existed in their three ways before the heaven, and that the nurse of generation (phase space), moistened by water and inflamed by fire, and receiving the forms of earth and air, and experiencing all the affections which accompany these, presented a strange variety of appearances and being, full of powers, which were neither similar nor equally balanced, was never in any part in a state of equipoise, but swaying unevenly hither and thither, was shaken by them, and by its motion, again, shook them, and the elements when moved, were separated and carried continually, some one way, some another.¹⁶

The result of this creative mixture is expressed in the creation of exemplars, which are metaphorically expressed by the five regular solids as they come into formation from the multiple-connectedness of the spherical generation.

This brings us to the more profound question relative to the uniqueness of the Platonic solids, which is: "Why are there only five regular solids, and why is it not possible to have more than five?" When you consider the solids in themselves, in their individual existence, you cannot help but notice that the minimal solid angle is the three-sided Tetrahedron, and the maximum solid angle is the five-angular grouping of the Icosahedron. These are the limiting conditions of their existence, but not for their spherical generation. (We shall examine later that the axiomatic flaw of Leonhard Euler with respect to generating solids lay precisely in not having understood the following generative principle of the sphere.) Now, we are ready to solve the anomaly of the 10-circle sphere. (See Figure 10.)

My first thought had been to build the 10-circle sphere of Pythagoras by adding the Cuboctasphere of 4 circles with the Icosidodecasphere of 6 circles. After all, 4 plus 6 makes 10. However, it did not work. This perplexed me for a long time. Why is it that this 10-circle sphere did not integrate all of the Five Platonic Solids? The spherical Golden Section was present, and so was the Cuboctasphere, but the Icosidodecasphere was no longer there? Whoever has attempted to construct the 10-circle sphere of Pythagoras, will find that the results can only be perplexing and disappointing. You can actually attempt to visualize the difficulty by putting 10 rubber bands around the 10 hexagonal planes cutting a Dodecahedron. This

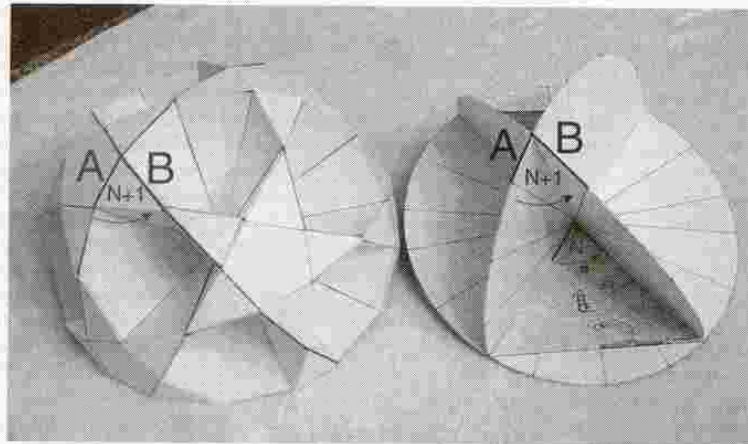

Figure 11
THE GREAT PYRAMID APEX ANGLE PROJECTED ON THE GREAT CIRCLE FROM THE HIGHER MANIFOLD OF THE 10-CIRCLE SPHERE

The shadow of the Great Pyramid's apex (marked N), established at 76 degrees, comes from the angle of projection onto the center of its hemispherical great circle by a starred pentagon located on the surface of the sphere (marked N + 1).

If you were to project a light source from outside the 10-circle sphere onto the curved edges of one of its spherical starred pentagons, the shadow angle formed by the side of the pentagon and its triangular extension, would project onto the center of that great circle, not a curved angle, but the apex angle of the Great Pyramid at 76 degrees.

seemingly useless effort, however, should not stop you from persisting in your obstinate quest.

10 The Multiply Connected Manifold Of the 10-Circle Sphere

In 1509, Luca Pacioli of Borgo San Sepulcro, published with Leonardo da Vinci, a book entitled *Divine Proportion*, in which they established an improved form of generation of the Golden Section, which provided the key to our problem. They had derived the Golden Section from the Pythagorean partitioning of the sphere, as opposed to deriving it from the plane. In other words, as they were looking for a generative form of *Divine Proportion*, they discovered that the Golden Section was primarily a reflection of living processes, as opposed to non-living processes. This higher integration of living processes caused an extraordinary reaction among the Gnostic-Cabalistic fraternities of Europe, at that time.

Pacioli and Leonardo, like Kepler after them, came under massive attack by the Venetian school of the Satanist Franciscan monk, Francesco Zorzi, whose cabalistic mysticism was aimed at destroying the Golden Renaissance and its influence in England, France, Italy, and Spain, primarily. This was the time when the pentagram, and its derived forms of linear Golden Section, began to be claimed by Gnostic secret societies as a satanic symbol, and the hexagram became the

symbol of the Jewish Cabala, and later the emblem of Martinism.

The point that Pacioli and Leonardo had emphasized was that the spherical generation of the Golden Section proceeded from the same intention as did living processes themselves; their proportions being derived principally, as demonstrated by Leonardo's depiction of man, inscribed in the great circle of a sphere by a mixture of six-sidedness and ten-sidedness. Leonardo's "Man Squaring the Circle" is a more advanced form of the paradox of the Great Pyramid. Similarly, the derivation of living processes from the geometry of the pentagon, and the non-living processes from the geometry of the hexagon, was rejected as being totally wrong, linear, and misleading. This was well illustrated by the treatment that Kepler later gave to the differences between living and non-living processes, in his admirable paper on the *Snowflake*. Kepler stated, "For just as God is the model and rule for living creatures, so the sphere is for solids."

A simple shadow-mapping of the Great Pyramid meridian triangle, projected on any circle of the 10-circle sphere (see Figure 11), shows how the pyramid slope angle of 52 degrees was chosen to determine the height of the Great Pyramid from such a sphere (Figure 12a). If the apex angle of the pyramid is 76 degrees, then it follows that the height of the pyramid must be to the perimeter of its base as a radius of the same height is to a circle.

This apex angle of 76 degrees, divided into two, then defines the 38-degree angle of the two observation shafts projected from the Queen's Chamber, both of which form right angles with the 52-degree slope of the Great Pyramid.

It should be further noted, that the six different 16-degree angle singularities of each circle represent the musical register-shifts of the six human voices, properly situated according to

their respective passing tones, within the natural 12-tone musical system. (See Figure 12b.)

In the Great Pyramid, the timing of the rising of stars above the horizon, and their precise passing at the meridian, were all expressed by a chiming system, orchestrated by observers sitting in appropriate positions on top of the truncated pyramid, as Proctor had imagined. Every hour marked on the clepsydra water clocks corresponded, very precisely, to the 12 tones of an ancient Egyptian musical chime system. In this way, the precise passing of stars was registered inside the Grand Gallery, and mapped onto a series of spheres. This was the musical proportionality that was later to become the basis for the Keplerian *Harmony of the Spheres*.

In musical terms, this meant that harmonic ordering could not be generated by the simple monochord, but by the higher manifold of register shifts of the six human voices. It was the introduction of this higher manifold of living processes, with respect to the Pythagorean spherics, that acted as a solution to the anomaly of the 10-circle sphere.

Thus, in summation, the angle of 60 degrees generates the Cube, the Octahedron, and the Tetrahedron; the spherical cross-circle angle of 36 degrees generates the Icosahedron and the Dodecahedron; and the angle of 76 degrees generates the Great Pyramid meridian triangle. Finally, the minimum angular determination of 16 degrees of the six-voice register shifts, mixed with the maximum of 16 great circles, pertains to the C-256 musical tuning, and also determines the integral angular composition of the *Icosa-dodeca-cubocta-khufu-sphere* of Pythagoras.

In geometrical terms, it is the spherical golden section mix of six-sidedness and ten-sidedness, which stands as the limit of packing of the Five Platonic Solids, within this single 16-circle integral sphere of positive curvature, and which also provides

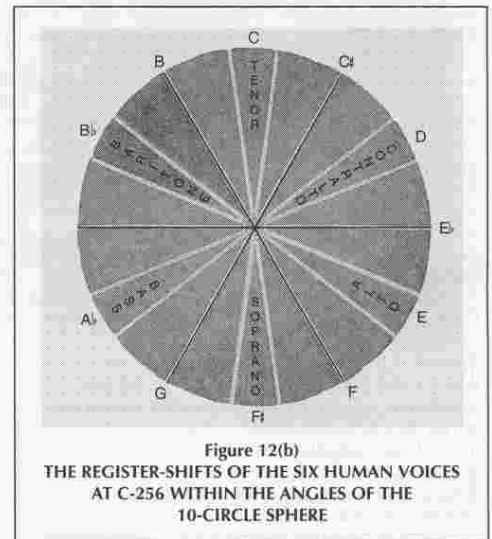
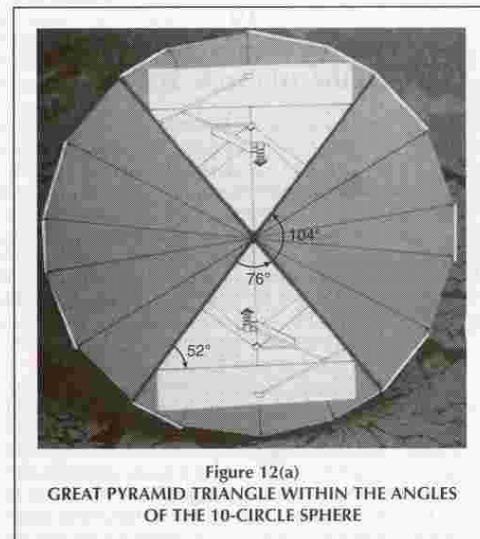

the measure for the Egyptian Great Pyramid calendar. A higher geometric construction was therefore required by the proportionality of 10 circles partitioning each other into 6 unequal parts, added to 6 circles partitioning each other into 10 equal parts. Thus, a single sphere of 16 great circles, entirely formed with Golden Sections, generates the five regular Platonic solids and creates the Great Pyramid Paradox from the higher power of the complex domain (Figure 13.)¹⁷

As a result, if we apply the calculations initiated by Kepler in the *Mysterium Cosmographicum*, we obtain the following:

10-circle sphere: Every 5 circles meet 12 times = 60
 Every 3 circles meet 60 times = 180
 Total = 240

6-circle sphere: Every 5 circles meet 12 times = 60
 Every 3 circles meet 20 times = 60
 Total = 120

Grand Total = 360 circular intersections

This makes a grand total of 360 multiply connected spherical intersections, a total corresponding to Imhotep's partitioning of the Egyptian Celestial Sphere for his great precession proportionality calendar that he partitioned into 360 days of the gods, and into 360 degrees.

Thus, 50 centuries ago, the *science of the Advantage of the other* was built by ancient Egyptians, to establish a relationship between man and God that would become a standard for scientific thinking. This was the link between the Egyptian and the Greek civilizations. The great proportionality between the sphere of the heavens and the Great Pyramid of Khufu (Cheops), stands not merely as a test of time, but as a living testament to the genius of the wisemen of ancient Egypt and ancient Greece—to their mutual applications of the principle of proportionality, and to the immortal collabora-

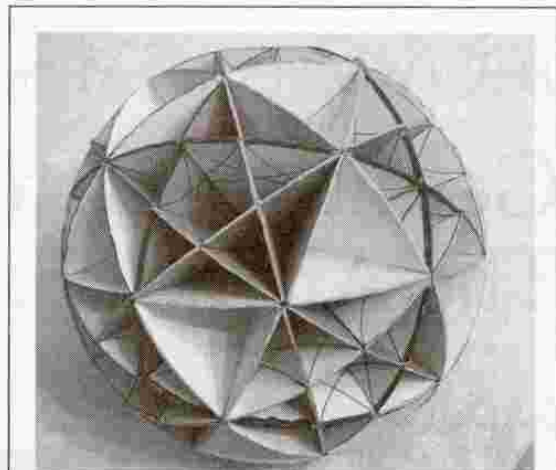

Figure 13
THE 16-CIRCLE SPHERE

This view of a 16-circle sphere shows both the cubic aspect of the Cuboctahedron (the four intersections outlined in dark color), and the pentahedral aspect of the Icosidodecahedron.

tion they have shared for the *Advantage of the other*, that is, for the benefit of all humanity, past, present, and future.

Pierre Beaudry is a geometer and political troublemaker. He has been associated with Lyndon LaRouche for the past 30 years.

Notes

- Bal Gangadhar Tilak, *Gita-Rahasya* (Bombay: Valbhav Press, 1935) Vol. 1, p. 536.
- As documented in EIR's Special Report (Dec. 2000), "Who Is Sparking a Religious War in the Middle East?," this same Zorzi plan is the source of the current drive by the British *Quatuor Coronati* freemasons to fuel religious war in the Middle East, under the pretext of restoring the Temple of Solomon on the Temple Mount in Jerusalem. Current Israeli Prime Minister Ariel Sharon and U.S. Vice President Dick Cheney serve as accomplices in this satanic, synarchist effort. This is the same Straussian Beast-Man of the Synarchy International, which controls both U.S. Vice-President Dick Cheney and the British Fabian Society, and has been spreading its fascist outlook around the world, sometimes under the guise of Socialism, sometimes under the guise of an Integralist fascism, such as was spewed out at the time of the French Revolution by Joseph de Maistre and his pseudo-Catholic secret society called Martinism.
- Gay Robins and Charles Shute, *The Rhind Mathematical Papyrus* (British Museum Publications, 1987).
- Gay Robins and Charles Shute, *op. cit.*
- Lyndon H. LaRouche, Jr., (transcript): "LaRouche to West Coast Cadre School: Only Man Can Discover Universal Principles," *New Federalist*, Vol. XVII, No. 6, Feb. 9, 2004, p. 5.
- Zbynek Zaba, as quoted in Peter Tompkins, *Secrets of the Great Pyramid* (New York: Harper Colophon Books, 1971).
- Peter Tompkins, *Secrets of the Great Pyramid* (New York: Harper Colophon Books, 1971), p. 152.
- Reference is to: Richard Anthony Proctor, *The Great Pyramid, Observatory, Tomb, and Temple* (London: Chatto & Windus, 1883).
- Peter Tompkins, *op. cit.*, pp. 155-156.
- Herodotus, *The History*, David Green, translator (Chicago: University of

- Chicago Press, 1987), 2:124, p.193.
- Nicholas of Cusa, *The Layman: About Mind* (New York: Abaris Books, 1979), p. 57.
- Johannes Kepler, *Mysterium Cosmographicum, The Secret of the Universe* (New York: Abaris Books, 1981), p. 61.
- Johannes Kepler, *op. cit.*
- Since I wrote this, Larry Hecht pointed out to me that there are two 10-circle spheres. In the one Kepler describes, the great circles intersect two-at-a-time over 30 vertices, three-at-a-time over 20 vertices, and five-at-a-time over 12 vertices. In the other 10-circle sphere, of which I built a model, there are 90 two-fold intersections, and the surface is partitioned into pentagonal stars (pentagons and isosceles triangles) and hexagons. In both cases, however, the same paradox arises: The great circles forming the figure are not divided into equal parts.
- Gottfried Wilhelm Leibniz, *Outline of a Memorandum: On the Establishment of a Society in Germany for the Promotion of The Arts and Sciences (1671)*, in Nancy Spannaus and Christopher White (eds.), *The Political Economy of the American Revolution*, (Washington, D.C.: Executive Intelligence Review, 1996), p. 215.
- Platon, *Le Timée*, in *Oeuvres Complètes, Société d'Édition* (Paris: Les Belles Lettres, 1970), p. 52.d. Rendered into English by the author.
- Pythagoras added two more spheres to this unique Celestial Sphere: a sphere of 4 circles partitioning each other into 6 equal parts, and a sphere of 3 circles partitioning each other into 4 equal parts. Thus, the complete system of planetary spheres of Pythagoras had no less than a total of 4 spheres and 23 great circles. We will develop, at another time, the significance of the Pythagorean sphere of 16 great circles with respect to the musical tuning at C-256. Furthermore, we also leave for another occasion the study of how the limiting Golden Section of spherical close packing is necessarily bounded by the constraint of the catenary and its characteristic negative curvature.

In This Issue



Frank P. Roy/2002 <http://egyptphoto.net.ca>

The Pyramid of Khufu at Giza, seen from the northwest corner. Inset: the 10-circle sphere from which the apex angle of the great pyramid is derived. This view highlights one of the star pentagons which cover its surface.

PYTHAGOREAN SPHERICS: THE MISSING LINK BETWEEN EGYPT AND GREECE

There is no mystery or "secret-knowledge" of the pyramid, as centuries of cultists and pyramidologists have alleged. As Pierre Beaudry elaborates in the featured article (page 48), only the open secret of the science of the Advantage of the other lies behind its construction and use.



Pierre Beaudry



The Vernadsky Geological Museum in Moscow, where the conference on "Science and Our Future" was held.



Halga Zepi-LaRoucha/EIRNS

IDEAS THAT WILL CHANGE THE WORLD PRESENTED AT MOSCOW CONFERENCE

The inevitability of mining asteroids, anti-gravitation, the possible renewability of oil reserves, and the effects of orbital electrons on nuclear stability were some of the featured papers at a three-day conference at the Vernadsky State Geological Museum in Moscow April 14-16. Our Conference Report, p. 78, reviews the research highlights.

